

# GEAR-UP

## Deliverable 1.1

### Demonstration & characterization requirements analysis and definition of key metrics

Deliverable Lead: Fraunhofer SCAI

Deliverable Due Date: 31.03.2025

Actual Submission Date: 31.03.2025

Dissemination: Public

Version: **1.0**

Published 31.03.2025



This project has received funding from the European Union's Horizon 2020 research and innovation programme under grant agreement n° 101178484. This document reflects only the author's view and the Commission is not responsible for any use that may be made of the information it contains.

## Project

Title	Acronym	Grant Agreement Nr.	Project Start	Project End
Green Engineering, Analysis, & Reskilling for Unbounded Production	GEAR-UP	101178484	01.10.2024	30.09.2028

## Deliverable

Name of deliverable	Deliverable nr.	Work package	Task
Demonstration & characterization requirements analysis	1.1	WPI Benchmarking, Requirements, and KPI elaboration	T1.1 Demonstration & characterization requirements analysis; Task 1.2 Definition of Key Metrics for Material, Process & Product

## Dates and Partners

Due date	Submission date	Main author	Contributing partners	Reviewers
31.March 2025	31.03.2025	Manel D Silva Lopez Klaus Wolf Sander Grønnerød Nicolas Macallister	ALL	Klaus Wolf and Vegard Brøtan

## Revisions

Version	Submission date	Comments	Author
v0.1	March 20, 2025	Developed together with input from all partners.	SINTEF, Eurecat, Fraunhofer, Cellucircle, Aerobase
Beta	March 31, 2025	Finalised layout, cleared comments, etc	Klaus Wolf, Sander Grønnerød
v1.0	March 31, 2025	Final review	Vegard Brøtan

## Abstract

D1.1 is the first deliverable of work package (WP) 1 and is divided into two tasks that:

- a) provide a demonstration and requirement analysis;
- b) details KPIs, metrics and criteria that serve as a foundational guide for subsequent project phases.

The first part of the document "Requirement Analysis", details the rationale, challenges, technology solutions and characterization requirements for each use case (UC). Technology readiness levels (TRLs) for each technology solution are noted, as well as planned improvements. Finally, a roadmap is drafted ensuring synchronization with development in WP5-WP6 and the WP7 validation plans.

The second part of the document "Key Metrics", identifies and quantifies parameters that will be important in the project. The parameters are classified according to their appropriate domain, either as material, process or product metrics. Finally, some of the key metrics in the form of key performance indicators (KPIs) are established, standing as overarching goals to reach throughout GEAR-UP.

## Keywords

Requirement analysis, challenges, technology solutions, characterization, technology readiness level, secondary material, recycled, material, process, product, composition, trace elements, LCA, uncertainty quantification, modelling, additive manufacturing, directed energy deposition, PBF, polymer, composite, stainless steel, aluminium

## Disclaimer

This document is provided with no warranties whatsoever, including any warranty of merchantability, non-infringement, fitness for any particular purpose, or any other warranty with respect to any information, result, proposal, specification or sample contained or referred to herein. Any liability, including liability for infringement of any proprietary rights, regarding the use of this document or any information contained herein is disclaimed. No license, express or implied, by estoppel or otherwise, to any intellectual property rights is granted by or in connection with this document. This document is subject to change without notice. GEAR-UP has been financed with support from the European Commission. This document reflects only the view of the author(s) and the European Commission cannot be held responsible for any use which may be made of the information contained.

## Acronyms and definitions

Acronym	Meaning
AM	Additive Manufacturing
AI	Artificial Intelligence
CET	Columnar to Equiaxed Transition
CF/TiO <sub>2</sub>	Carbon Fiber/Titanium Dioxide
CT	Computed Tomography
DED-LB/W	Directed Energy Deposition – Laser Beam/Wire
EBSD	Electron Backscatter Diffraction
EoL	End-of-Life
EPD	Environmental Product Declaration
ESG	Environmental, Social and Governance
FEM	Finite Element Method
KPI	Key Performance Indicator
LCA	Life Cycle Assessment
LCI	Life Cycle Inventory
LCIA	Life Cycle Impact Assessment
LOM	Light Optical Microscopy
LPM	Laser Power Monitoring
ME-FRP	Material Extrusion – Fiber Reinforced Polymer
ML	Machine Learning
MPM	Melt Pool Monitoring
PBF-LB/M	Powder Bed Fusion – Laser Based/Metal
PCR	Product Category Rules
PWHT	Post Weld Heat Treatment
SEM	Scanning Electron Microscope
TRL	Technology Readiness Level
UC	Use Case
UQ	Uncertainty Quantification
WP	Work Package

## About the GEAR-UP project

The GEAR-UP proposal aims to revolutionize manufacturing with sustainable practices and advanced technologies. It focuses on developing digital tools to manage recycled materials variability in stainless steel, aluminum alloys, and fiber-reinforced plastics for additive manufacturing. The project uses simulation-driven approaches to optimize AM processes like laser beam-directed energy deposition, metal laser beam powder bed fusion, and fiber-reinforced polymer material extrusion.

GEAR-UP emphasizes environmental conservation by incorporating recycled materials in engineering design, reducing the use of virgin resources, energy consumption, and greenhouse gas emissions. It addresses challenges with secondary materials through resilient design and life-cycle environmental impact assessment. The proposal also aims to enhance sustainable product design with innovative simulation and modeling software, implement the Digital Product Passport initiative, and promote circularity and sustainable technology adoption through training and global collaboration.

This initiative represents a shift in engineering design, focusing on the circular value chain and developing adaptable AM technologies resilient to material variability, impacting high-performance consumer products, green energy, and high-tech robotics market.

## Table of Contents

Project.....	1
Deliverable .....	1
Dates and Partners .....	1
Revisions .....	1
Abstract.....	2
Keywords.....	2
Disclaimer.....	3
Acronyms and definitions.....	4
About the GEAR-UP project.....	5
1 Requirement Analysis – Rationales.....	9
1.1 Use case Robot gripper.....	11
1.1.1 Rationale .....	11
1.1.2 Challenges.....	14
1.1.3 Technology Solution.....	16
1.1.4 Quality Control and Metrology.....	18
1.2 Use case Pelton Turbine .....	20
1.2.1 Rationale .....	20
1.2.2 Challenges.....	23
1.2.3 Technology Solution.....	25
1.2.4 Quality Control and Metrology.....	28
1.3 Use case Drive Sprocket of Composite from recycled textiles .....	30
1.3.1 Rationale .....	30
1.3.2 Challenges.....	32

## D1.1. Demonstration & characterization requirements analysis

1.3.3	Technology Solution.....	33
1.3.4	Quality Control and Metrology.....	35
2	Requirement Analysis – Solution Technologies.....	37
3	Requirement Analysis – Solution Roadmap.....	42
4	Requirement Analysis – AI powered LCA Roadmap.....	45
5	Requirement Analysis – Stakeholders’ Workshop.....	50
6	Key Metrics Task 1.2.....	52
6.1	Key Metrics for the Materials.....	53
6.1.1	Robot Gripper – Material metrics.....	54
6.1.2	Pelton Turbine – Material Metrics.....	55
6.1.3	Composite with recycled textiles – Material Metrics.....	57
6.2	Key Metrics for the Processes.....	59
6.2.1	Robot Gripper – Process Metrics.....	59
6.2.2	Pelton Turbine bucket head – Process Metrics.....	60
6.2.3	Composite with recycled textiles – Process Metrics.....	62
6.3	Key Metrics for the Products.....	63
6.3.1	Robot Gripper – Product Metrics.....	63
6.3.2	Pelton Turbine – Product Metrics.....	64
6.3.3	Composite with recycled textiles – Product Metrics.....	66
6.4	Conclusion on key metrics.....	67

## List of Figures

Figure 1: Robot gripper that has been manufactured with Ti-6Al-4V.....	11
Figure 2: Pelton turbine bucket.....	20
Figure 3 Electrical snowmobile from Vidde Snow Mobility(a) Drive sprocket (b).....	30
<i>Figure 4. Solutions classified by engineering domain.....</i>	<i>43</i>
Figure 5. Interaction between solutions and major work packages .....	44
Figure 6. a) Drive sprocket geometry with the distance from center to the center area of contact. b) Predicted stresses in Drive sprocket during maximum load.....	66

## List of Tables

Table 1: Overview of tests that will be carried out on AlMg10Si coupons .....	18
Table 2: Overview of tests for pelton turbine.....	28
Table 3. Overview of tests that will be carried out on polymer samples and on printed products.....	35
Table 4: Technology solutions for robot gripper.....	37
Table 5: Technology solutions for pelton turbine.....	39
Table 6: Technology solutions for composites from recycled textiles .....	41
Table 7: Overview of LCA-specific parameters .....	48
Table 8: Standard composition for AlSi10Mg powder .....	54
Table 9: Compositions that imitate secondary material with recycled contents....	55
Table 10: The desired range of composition in 13-4 soft martensitic stainless steel .....	56
Table 11: Process metrics used in production of robot gripper.....	59
Table 12: Process metrics for repaired section of pelton bucket head, manufactured by DED-LB.....	60
Table 13: Process metrics for 3D-printed Drive Sprocket for Snow Mobile drive train .....	62
Table 14: Product metrics for the robot gripper.....	63
Table 15: Product metrics for the repaired section of Pelton turbine bucket head..	65

# 1 Requirement Analysis – Rationales

## Task 1.1 Demonstration & characterization requirements analysis

**Phase 1:** This Task will organize a preliminary workshop with key stakeholders of the GEAR-UP solution. The use-case (UC) rationales, industries' problems, and challenges will be captured on paper, voted for significance, and formalized, thus refining the high-level vision of the GEAR-UP solution. This activity aims to detail the GEAR-UP concept captured during the proposal preparation phase and revise it in depth, ensuring no gaps, logical inconsistencies, or unrealistic ideas exist.

We held several web-meetings per use case:

- Metal AM – PBF-LB of robot gripper (AlSi10Mg)
- Metal AM – DED-LB/W of Pelton Turbine (13-4 stainless steel)
- Composite AM – ME-FRP (Polymer-CF/TiO<sub>2</sub>)

During each of these UC specific meetings, we covered the following topics:

- RATIONALE:
  - More details (qualification, quantification) about
  - material: new, recycled, availability, quality ranges, energy parameters,
  - manufacturing processes: practicality, costs, energy, material consumption, waste streams/effluents, water consumption
  - virtual engineering: suitable models simulation capabilities, material models, material database,
- CHALLENGES:
  - Clearly define (quality, quantification) the risks
- SOLUTION:
  - Evaluate, refine and rate each of the proposed solution methods
- METROLOGY: More details (qualification, quantification)
  - Practicality, availability, reliability, costs
- DATA:
  - Available public data & information, background data from partners, foreground data to be generated during project, data access only private/community/open
- Summary:
  - Common problems and goals

## D1.1. Demonstration & characterization requirements analysis

- UC specific issues
- Define general/UC specific parameters to calculate overall costs and ESG parameters

For each UC, the GEAR-UP proposal is used as a basis for rationale, challenges and technology solutions. Excerpts from the proposal are listed, formalized and further described through input from the appropriate consortium members.

In the document the terms secondary, recycled and scrap in different context. In order to clarify the different intentions that authors gave to these words, in general, the terms secondary material/alloy is used when the authors refer to the material and alloy produced, the powder or final material obtained after the alloy processing. The terms recycled material or scrap are used when the authors referred to the raw material used to produce the alloy, the inputs used for the alloy processing.

## 1.1 Use case Robot gripper

Use case - Part 1	Metal AM – PBF-LB of robot gripper (AlSi10Mg)		
Manufacturing Partners	SINTEF, EUT, 3DP [3 compositions]	Tech. Par.	AER, FPS

### 1.1.1 Rationale

Being heavily reliant on titanium for manufacturing with laser-based powder bed fusion (PBF-LB), “3D production AS” is now exploring the use of other materials with the overarching goal of creating ‘greener’ parts. Aluminum is a particularly promising material, due to its light weight, affordability, recyclability and diverse set of properties. Primary production of both titanium and aluminum are energy intensive processes with profound environmental impacts. By utilizing recycled aluminum, we expect to establish a far more sustainable production line.

The final product that will be manufactured is a robot gripper as seen in Figure 1, which is expected to be slightly bulkier when produced with recycled aluminum.



*Figure 1: Robot gripper that has been manufactured with Ti-6Al-4V*

To explore variability in properties induced by both secondary materials, and the AM process, extensive testing will be done at the coupon level, described in detail in section 1.2.4 Some tests are not directly linked to the degradation mechanisms experienced by a robot gripper, e.g. corrosion, but will provide a great foundation for acquiring data on the possibilities of future applications in other parts.

## D1.1. Demonstration & characterization requirements analysis

Gear-Up-Proposal: *“3D production relies heavily on titanium for manufacturing with powder bed fusion (PBF). They use titanium to create various components, including bike parts, robot grippers, and hunting gun silencers”*

- The focus will be on grippers that are currently made in Ti.

Gear-Up-Proposal: *“However, there are some drawbacks to using titanium. Titanium has a complex and energy-intensive extraction and purification process, contributing to its high price tag. ”*

- There is no change in rationale, by exchanging titanium with recycled aluminum we foresee a far more sustainable and economically viable production line.

Gear-Up-Proposal: *“On the other hand, aluminum is abundant in the earth’s crust and the energy required for extraction and refining is relatively low, resulting in moderate production costs. ”*

- As far as we can see this is still valid. We have some good reports that expect the energy needed decrease a somewhat more, use more recycled aluminum and transition to renewable energy, further lowering CO<sub>2</sub> footprint.

Gear-Up-Proposal: *“It is 60% lighter than the commonly used titanium alloy, Ti-6AL-4V. However, AlSi10Mg does not exhibit the same strength-to-weight ratio as titanium. ”*

- There is no change in rationale.

Gear-Up-Proposal: *To address environmental concerns, 3D production is now exploring using recycled aluminum, a significant portion of the finer powder tends to be carried away with the shielding gas to the gas filters.*

- There is no change in the rationale.

Gear-Up-Proposal: *“Thus, a fraction of larger particles will help mitigate losses during the PBF process. ”*

- There is no change in the approach.

## D1.1. Demonstration & characterization requirements analysis

Gear-Up-Proposal: *"The resulting 'green series' parts are expected to be faster to produce, more cost-effective, and slightly bulkier than their titanium counterparts while maintaining their essential functions."*

- There is no change in the goal.
- Different chemistries to be produced and tested.

### General issues and questions

- We need detailed material definitions: new, recycled, availability, quality ranges, energy parameters,
- Question on lifetime: one would expect the lifetime of a Ti-6Al-4V component to far exceed one made from AlSi10Mg. To what extent would this affect the LCA?
- Manufacturing processes: practicality, costs, energy, material consumption,
- Virtual engineering: suitable models simulation capabilities, material models, material database

## 1.1.2 Challenges

Gear-Up-Proposal: *"AlSi10Mg size distribution for faster production with less waste to filters. "*

- There is no change to the challenge, proposed strategies such as larger powder size and lower gas flow rate will be tested.

Gear-Up-Proposal: *"Dealing with impurities in recycled materials: recycled materials need to meet same specs as materials from primary usually. "*

- There is no change in this challenge. Standard compositions will not be adhered to in the recycled material. Regardless of this fact, GEAR-UP will generate a solid body of scientific data aimed at optimizing material properties and the printability of the powder. With increased knowledge of the effects of trace elements, recycled material can be more easily implemented in supply chains.

Gear-Up-Proposal: *"Process parameters for small chemistry changes."*

- There is no change, process parameters need to be optimized.

Gear-Up-Proposal: *"Material property deviations due to trace elements."*

- Quality deviations, and how they can be quantified: particle size, mechanical properties

Gear-Up-Proposal: *"Acceptable (chemical) element contents for the process "*

- Meant here are variations in chemistry

Gear-Up-Proposal: *"Process-specific problems due to trace elements "*

- Will be evaluated during project progress

## D1.1. Demonstration & characterization requirements analysis

Challenge: *Difference in material properties between Ti-6Al-4V and AlSi10Mg*

- AlSi10Mg does not exhibit the same strength-to-weight ratio as Ti-6Al-4V, requiring extra thickness for equivalent applications.
- Differences in durability between the two materials will need to be quantified for lifetime estimates.

Challenge: *Effect of trace elements on manufacturing processes, variability and material properties*

- Compositions containing increased amounts of trace elements may make AlSi10Mg more prone to hot cracking and other defects.
- Fine tuning process parameters (e.g. scan speed, build plate temperature etc.) will ensure consistency and lower variability between batches.

Challenge: *Adequate heat treatment to ensure optimal properties*

- Cast AlSi10Mg is usually age hardened to increase strength. AM (additive manufacturing) differs from casting in this respect, as the fine as-built microstructure produced by high cooling rates, may lose strength upon age hardening. Adequate heat treatment that is tailored to AM and recycled aluminium will need to be defined to achieve desired properties.

### 1.1.3 Technology Solution

Gear-Up-Proposal: *“Modelling the variability due to the increased concentration of trace elements”*

- **UC1-1:** Development of detailed material models that capture the effects of trace elements on the material properties and printability of AlSi10Mg.
- **UC 1-2:** Additions of alloying elements that may exhibit a positive effect on the powder used for printing.

Gear-Up-Proposal: *“Building components that are resilient to variation in properties.”*

- 3DP will check during process progress.

Gear-Up-Proposal: *“Applying melt pool monitoring to investigate thermal problems in the process. ”*

- **UC 1-3:** Integrate in-situ monitoring such as melt pool monitoring (MPM) and laser power monitoring (LPM) to provide valuable input for simulations. Gain an increased understanding of results based on subsequent characterization.

Gear-Up-Proposal: *“Geometry optimization for AM and printing strategy optimization with the help of FEM process simulations ”*

- **UC 1-4:** CAE tools and finite element methods (FEM) will be used to optimize printing strategies and thermal profiles. Simulations will identify optimal processing parameters to limit defects and achieve desired microstructural morphology.

Gear-Up-Proposal: *“Combine characterization and material modelling with process simulations to predict microstructure, optimize process parameters, and eliminate scatter and property variations in the component. ”*

- **UC 1-5:** Carry out tensile, hardness, fatigue, corrosion tests and advanced microscopy to ensure that the material is sound for various applications.
- **UC 1-6:** Use the gathered data, coupled with CAE and FEM to iteratively identify optimal process parameters and design to the highest possible quality.

## D1.1. Demonstration & characterization requirements analysis

Predicted material properties and deformation from the manufacturing simulation (FEM) will be used as input in the functional analysis.

Gear-Up-Proposal: *“Modelling of the propagation of uncertainty based on the manufacturing process and component design to increase the understanding of additively manufactured components.”*

- **UC 1-7:** Identify suitable UQ parameters that will be passed from manufacturing to product simulation. Variation in microstructure and/or grain size are expected which give variation in strength and elongation.

Gear-Up-Proposal: *“Heat treatment design to meet the required part performance.”*

- **UC 1-8:** Undergo testing with different heat treatments, if necessary, to achieve a compromise between ductility and strength.
- **UC 1-9:** The components may be subjected to machining in critical areas, where as-built surface roughness and porosity are detrimental to mechanical properties. Interactions between material properties and as-built surfaces may be evaluated and optimized.

Additional solutions: *“Structured documentation of the PBF-LB/M process.”*

- **UC 1-10:** We will utilize MODA and CHADA documentation styles.

Additional Solutions UC 1-14: *“Semantic Concepts and information platform.”*

- **UC 1-11:** Standards will be evaluated, and data interfaces and semantic concepts for federated dataspace will be defined.
- **UC 1-12:** In addition, a reference architecture will be designed for the GEAR-UP platform.

### 1.1.4 Quality Control and Metrology

An overview of the tests that will be conducted on coupons representative of the robot gripper are provided in Table 1. These are closely connected to the key material, process and product metrics presented in section 6, where preliminary values and acceptance criteria are presented as benchmarks to be achieved through GEAR-UP.

Table 1: Overview of tests that will be carried out on AlMg10Si coupons

Testing method	Why tests are being done and how results are used for assessment	Number of tests
Fatigue	Fatigue testing establishes how well the material will withstand cyclic loads. It is used to project the fatigue-driven lifetime of a component for a given load scheme (cycles to failure).	15 accelerated fatigue tests will be conducted validated with 45 conventional ones
Computed tomography (CT)	CT provides a 3D-representation of porosities in selected coupons. Porosity/defects may worsen corrosion resistance and mechanical properties.	10
Nano/micro indentation	Used to accurately measure hardness with high resolution. Can be used to evaluate intermetallic precipitates	3
Light optical microscopy (LOM)	LOM is a highly versatile characterization technique, capable of initial identification of phases and grain morphology in a deposited sample.	50
SEM and/or EBSD	SEM is capable of secondary electron (SE), backscattered electron (BSE) imaging and energy dispersive spectroscopy. BSE can be used to identify precipitates. SE gives high resolution topography. EBSD can identify the crystallographic orientations of grains to evaluate	5

## D1.1. Demonstration & characterization requirements analysis

	texture, where solidification textures and anisotropy oftentimes are caused by AM.	
Tensile testing	Standard tests used to evaluate strength parameters, elongation and area of reduction.	30
Corrosion tests	Corrosion tests will be done in a 3.5% NaCl solution, and corrosion potentials with current densities will be evaluated.	4
Charpy impact tests	Impact tests will evaluate the material's resistance to sudden forces	
Melt pool monitoring data	MPM gives a qualitative description of thermal differences in parts during deposition. With increased knowledge of the data, it could be correlated to the occurrence of defects in the deposited sample.	30
Tests for powder sphericity, flowability and density	These tests will ensure that powders with trace elements are of high quality.	20

## 1.2 Use case Pelton Turbine

Use case - Part 2	Metal AM – DED-LB/W of Pelton Turbine (13-4 stainless steel)	
Manufacturing Partners	SINTEF, WAG, AKS [3 compositions]	AER, FPS

### 1.2.1 Rationale

Aker Solutions contributes to the Norwegian service market for hydro-turbines valued at 2-30 million EUR, which forms part of the larger European market estimate at 100 million EUR. Manufacturing these hydro-turbines currently constitutes forged 13-4 stainless steel material reduced into the final shape through traditional milling processes. This generates a significant amount of material waste, leading to a larger environmental footprint and increased costs. Furthermore, when the turbines break or reach end-of-life they are either refurbished or completely replaced. Advanced manufacturing solutions, such as automated robot welding, could lead to higher quality refurbishment compared to traditional welding processes, and the possibility to manufacture complete parts with significantly less machining requirements which may reduce material spending by 50-80 %. Furthermore, pairing advanced manufacturing with recycled material feedstock, from e.g. swarf, could increase the circularity of Aker's production line and significantly improve the environmental footprint with an estimate potential of 50-100 tons of available material for reuse per year.

The final product that will be refurbished/manufactured is a Pelton turbine bucket as seen in Figure 2. Furthermore, if successful the application could be extended to the manufacture of a Francis turbine.



Figure 2: Pelton turbine bucket

Gear-Up-Proposal: *“Norway’s service market for hydro-turbines is 2-30 million EUR. In Europe, the estimated market size is approximately 100 million EUR. In some instances, entire turbines are replaced with new technology, while in others, units undergo refurbishment to restore them to their original condition through repair processes.”*

- no updates

Gear-Up-Proposal: *“Everyday repair tasks include addressing sealings, runners, and head- and bottom covers, which may require workshop-based repair welding and machining.”*

- There will be seasonal variations

Gear-Up-Proposal: *“An intriguing possibility lies in automation—specifically, an automated robot welding system. This approach could yield higher-quality results, especially compared to traditional welding processes.”*

- Potential areas for automation are scanning, welding (improved lasers at SINTEF e.g. with faster cool-down rates) and 3D build-up, new machines with easier path planning
- reference surfaces are on the center layer

Gear-Up-Proposal: *“By reusing more material, we can significantly improve the environmental footprint.”*

- roughly 50-100 tons of waste material reused per year could be possible

Gear-Up-Proposal: *“Moreover, if successful, this process could extend beyond refurbishment and be employed in producing new components.”*

- There are some first ideas for Francis turbines

Gear-Up-Proposal: *“Additionally, additive production can potentially revolutionize Aker Solutions’ production methods. By reusing more material, we can significantly improve the environmental footprint.”*

- save more materials instead of machining it away, doing it onsite for grinding only (question of space in machine hall).

## D1.1. Demonstration & characterization requirements analysis

Gear-Up-Proposal: *"By utilizing additive techniques, they might reduce material spending by 50-80% compared to traditional milling processes. "*

- especially for Francis turbines currently 50-80% is milled away, if this can be avoided we would gain a lot; for Pelton turbines value is about 50%

Gear-Up-Proposal: *"If this process meets the necessary qualifications, Aker Solutions could also apply the technology to offshore deliveries, where machining errors are intolerable, and any imperfections would currently require complete reproduction."*

- technology could be used for different products offshore

## 1.2.2 Challenges

Gear-Up-Proposal: *"Heat impact on the Pelton turbine material; Thermal-dependent parameters for larger parts."*

Gear-Up-Proposal: *"Dealing with impurities in recycled materials: Flexible process parameters for small chemistry changes."*

Gear-Up-Proposal: *"Material property deviations."*

Gear-Up-Proposal: *"Acceptable element contents for the process"*

- There is no change to the aforementioned challenges. There is a need to identify trace elements that are picked up through Aker's production line, before evaluating their effects on the material.

Challenge: *Difference in material properties between forged 13-4 based material and material produced through additive manufacturing*

- Rapid solidification in additive manufacturing produces microstructures characterized by columnar grains compared to more equiaxed grain structures of traditional manufacturing.
- Different structures of refurbished material may lead to a mismatch in mechanical behavior in the refurbished turbine.
- During repair, the forged substrate will be affected by the heat induced by the welding process, which may affect the material negatively.

Challenge: *The effect of trace elements and impurities in recycled material on the manufacturing process, variability, and material properties.*

- Compositions from recycled material containing impurities or increased/decreased amounts of trace elements may affect the phase transformations and structure of the material. This could decrease the overall mechanical performance of the part.
- A different material composition may affect the solidification, thermal conduction and absorption properties of the material, which may require tuning of process parameters.

## D1.1. Demonstration & characterization requirements analysis

### Challenge: *Heat treatment to ensure optimal properties*

- While adequate post weld heat treatment (PWHT) is described in applicable welding standards, targeted heat treatment of welded material may be difficult and base forged material may be affected.

### Challenge: *Environmental degradation*

- Operation in freshwater hydro-power generation requires material to be resistant to erosion and corrosion effects from pH levels, high flow velocities, silt and debris, and other aggressive species.

### 1.2.3 Technology Solution

Gear-Up-Proposal: *"Modeling the variability due to the increased concentration of trace elements"*

- **UC2-1** Selection and production of wire feedstock either from, or emulating, real world recycled compositions with different chemical compositions, impurities and/or morphologies.
- **UC2-2** Development of detailed material modeling with process simulations for fabrication using 13-4 feedstock material in additive manufacturing, extended to include the effects of trace elements on material properties and printability.

Gear-Up-Proposal: *"Building components that are resilient to variation in properties"*

- **UC2-3** Identifying components and areas suitable for repair and production which are more resilient to variations in properties and suited to AM. By identifying sensitive areas such as connections of blades and rings and/or thin/thick walled this can guide where the integration of AM technology is suitable.

Gear-Up-Proposal: *"Geometry optimization for AM and printing strategy optimization with the help of FEM process simulations"*

- **UC2-4** Finite element methods (FEM) will be used to optimize deposition strategies and thermal profiles to limit distortions. Simulations will help provide optimal processing parameters to create components resilient to variation in properties. This will help ensure longevity and minimize techno-economic costs associated with part fabrication

Gear-Up-Proposal: *"Process monitoring during building to identify critical areas where defect formation is prone to occur, such as hot and cold spots."*

- **UC2-5** Integrate in-situ monitoring such as thermal imaging to provide input for simulations and aid in identifying areas where defects and distortions are prone to form.

## D1.1. Demonstration & characterization requirements analysis

Gear-Up-Proposal: *“Combine characterization and material modeling with process simulations to predict microstructure, optimize process parameters, and eliminate scatter and property variations in the component.”*

- **UC2-6** One way process data mapping to predict microstructure, optimize process parameters, and eliminate scatter and property variations in the component.
- **UC2-7** Carry out tensile, hardness, fatigue, corrosion and erosion tests and advanced microscopy to ensure sound material and application requirements.

Gear-Up-Proposal: *“Modelling of the propagation of uncertainty based on the manufacturing process and component design to increase the understanding of additively manufactured components.”*

- **UC2-8** Identify parameters passed from manufacturing to product simulation. Due to the variation in thermal history in thick and thin sections, variation in yield limit and hardness are expected

Gear-Up-Proposal: *“Heat treatment design to meet the required part performance.”*

- **UC2-9** Selection of heat treatments corresponding to AM material to align with use case environment and performance requirements.
- **UC2-10** Explore potential of surface treatments, such as hardfacing, using an automated robotic welding system. Developing this for selected areas in refurbishment and production potentially could improve part performance.

Additional solutions: *“Structured documentation of the six laser DED-LB/W process.”*

- **UC2-11** Incorporate structured documentation of the PBF-LB process, MODA and CHADA style.

## D1.1. Demonstration & characterization requirements analysis

- **UC2-12** Standards will be evaluated, and data interfaces and semantic concepts for federated dataspace will be defined. In addition, a reference architecture will be designed for the GEAR-UP platform.

## 1.2.4 Quality Control and Metrology

Table 2: Overview of tests for pelton turbine

Testing method	Why tests are being done and how results are used for assessment	Number of tests
Fatigue	Fatigue testing establishes how well the material will withstand cyclic loads. It is used to project the fatigue-driven lifetime of a component for a given load scheme (cycles to failure).	>45 conventional  >15 accelerated
Computed tomography	CT provides a 3D-representation of porosities in selected coupons. Porosity/defects may worsen corrosion resistance and mechanical properties.	20
Nano/micro indentation	Used to accurately measure hardness with high resolution. Can be used to evaluate intermetallic precipitates	3
Light optical microscopy	LOM is a highly versatile characterization technique, capable of initial identification of phases and grain morphology in a deposited sample.	50
SEM and/or EBSD	SEM is capable of SE, BSE imaging and energy dispersive spectroscopy. BSE can be used to identify precipitates. SE gives high resolution topography. EBSD can identify the crystallographic orientations of grains to evaluate texture, where solidification textures and anisotropy oftentimes are caused by AM.	5

## D1.1. Demonstration & characterization requirements analysis

Tensile testing	Standard tests used to evaluate strength parameters, elongation and area of reduction.	30
Corrosion tests	The erosion-corrosion experiment should ideally be representative of service conditions - freshwater with varying compositions of sand. Evaluation of the surface with SEM, LOM and infinite focus microscope with quantifications of mass loss.	4
Charpy impact tests	Impact tests will evaluate the material's resistance to sudden forces	30
Fracture toughness	These tests will measure the materials resistance to brittle fracture	3
Single bead-on-plate	Initial tests for process parameter selection for stable deposition with no defects	50
Multi-layer deposit	The secondary development step involves creating more complex geometries, such as walls, to further optimize process parameters. This step helps in understanding deposition paths and managing thermal effects more effectively.	100
Thermal Camera analysis	Integrated thermal monitoring will be used to help understand the thermal profile of the melt pools and bulk material, aiding in defect detection and process optimization	30

## 1.3 Use case Drive Sprocket of Composite from recycled textiles

Use case - Part 3	Composite AM –ME-FRP (Polymer-CF/TiO <sub>2</sub> )	
Manufacturing Partners	CCR, C4P [3 compositions X 2 material systems]	AER, FPS

### 1.3.1 Rationale

Vidde Snow Mobility AB is developing electrical utility snowmobiles for the arctic climate. Today, most of the snowmobiles are powered by two- or four-stroke engines. Vidde is creating the next generation solutions for terrain vehicles, built to drive the mobility transition and significantly reduce CO<sub>2</sub> emissions. The vehicles are designed for high performance, low maintenance and a long life in service which is the key to low environmental impact. The electrical drivetrain creates less noise and higher torque at low RPM than in a snowmobile with a combustion engine. The new conditions require new ecofriendly design solutions for the drive shaft and sprocket. The existing drive sprocket is shown in Figure 3b.



a)



b)

Figure 3 Electrical snowmobile from Vidde Snow Mobility(a) Drive sprocket (b)

## D1.1. Demonstration & characterization requirements analysis

Gear-Up-Proposal: *"There are significant efforts today in recycling polymeric materials, and many successful existing technologies focus on nanomaterials and composites with low reinforcement content or with nano-scaled reinforcements in the nanoscale. "*

- There are no further updates in rationale.

Gear-Up-Proposal: *"The recent demands to develop circular materials have put significant pressure on recycling polymeric systems with varying compositions and high heterogeneity. "*

- There are no further updates in rationale.

Gear-Up-Proposal: *"GEAR-UP project will develop a highly complex and heterogeneous composite system based on recycled textiles with high (nano)cellulose content based on the patented technology from CelluCircle and use it for the 3D printing of high-performance and/or high-volume materials."*

- There are no further updates.

### 1.3.2 Challenges

Gear-Up-Proposal: *"High level of heterogeneity and complexity in the recycled materials"*

- There are no further updates.

Gear-Up-Proposal: *"The challenges related to property degradation during recycling and circular use of recycled materials."*

- There are no further updates.

### 1.3.3 Technology Solution

Gear-Up-Proposal: *“Modelling of the effect of the addition of biopolymers (biobased polyurethane, PBAT, PLA) recycled carbon fibers as well as inorganic additives to the recycled textile masterbatches on the mechanical performance “*

- (AER) Biopolymers and recycled carbon fibers would be new in available models

Gear-Up-Proposal UC3-1: *“The morphology (microscopy), mechanical properties (tensile tests) and chemical interactions (spectroscopy, dynamic mechanical thermal analysis) combined with AI-based tools to tune the material performance for a specific application to enable the use of recycled heterogeneous polymeric systems in mainstream manufacturing sector.”*

- CelluCircle will do chemical reactions, provide master batches (pellets after extrusion) with cellulose fibers & polyester with data.
- Colfeed will provide melt rheology for master batches, filaments characterization,

Gear-Up-Proposal UC3-2: *“3D printing to develop products with prescribed properties, taking advantage of directionality, hierarchical porosity, print patterns, and combination of materials supported by AI-based design.”*

- There are no further updates

Gear-Up-Proposal UC3-3: *“Develop recyclability and circularity by exploiting the concept with trimeric polymers with ‘Covalent adaptable networks’ applied to matrix biopolymers such as PLA, PBAT, and PU.”*

- Slightly changed solution: develop recyclability through remelting of the filaments and 3D printing components

Gear-Up-Proposal UC3-4: *“Thermally reversible bonds based on Diels –Alder reaction can impart higher modulus and lower elongation or enhance toughness if tailored carefully.”*

- There are no further updates

## D1.1. Demonstration & characterization requirements analysis

Gear-Up-Proposal UC3-5: *"This development of such a thermally reversible covalently bonded composite system will be a game changer in the circular design of additive manufactured FRP with tunable properties."*

- There are no further updates

Additional Solutions UC3-6: *"Semantic Concepts and information platform "*

- Standards will be evaluated, and data interfaces and semantic concepts for federated dataspace will be defined.
- In addition, a reference architecture will be designed for the GEAR-UP platform.

### 1.3.4 Quality Control and Metrology

Mechanical properties and hardness are evaluated on printed samples using filament wire. The component will be manufactured using polymer pellets and a higher feeding rate. These are closely connected to the key material, process and product metrics presented in section 6, where preliminary values and acceptance criteria are presented.

Table 3. Overview of tests that will be carried out on polymer samples and on printed products.

Testing method	Why tests are being done and how results are used for assessment	Number of tests
XCT-Scans	Defects identification	30
Optical & SEM Microscopy	CelluCircle: Examination of the structure of the filaments and 3D printed objects	30
Tensile/Compression/Impact	Colfeed: Evaluation of Young's modulus (stiffness), ultimate tensile strength and elongation (failure strain) in the build and perpendicular to the build direction for filaments and 3D printed objects. Determine the influence of the different additives on the mechanical properties	200
Functional property only for TiO <sub>2</sub>	Colfeed: Evaluation of the dispersion of the particles into the polymer and the photocatalyst capability using Methyl Orange as indicator.	3
Spectroscopy FTIR	CelluCircle: Identification of the bonds in the initial fiber material and after extrusion	15
Rheology	Colfeed: Determination of the flow behavior of the melted masterbatch and its combinations with other organic thermoplastic additives	14

## D1.1. Demonstration & characterization requirements analysis

	(PLA, PEG, etc...) as well as with the TiO <sub>2</sub> and recycled Carbon Fibers	
Nanoindentation	Determination of the hardness of the filaments with the presence of inorganic particles.	12
X-Ray diffraction	Analyze the crystalline structure and phase composition of polymer materials by measuring the diffraction patterns of X-rays passing through the sample	12

## 2 Requirement Analysis – Solution Technologies

### Task 1.1 Demonstration & characterization requirements analysis

**Phase 2** of this activity will capture the current GEAR-UP technology state and evaluate the necessary technology readiness levels (TRLs). A form of gap analysis will define a development roadmap toward realizing the conceptual vision.

In the following three tables, the indices ‘UC i-n’ refer to the solutions listed individually in the ‘Use Case ‘x’ – Technology Solutions’ chapter.

Table 4: Technology solutions for robot gripper

UC solution	Technology Solution	Type	Partner	TRL now	Planned Improvements	TRL final
UC 1-1	Modelling the variability of trace elements	Model	AER, FPS	4	Model validated in combination with PBF-LB	6
UC 1-2	Addition of alloying elements to improve powder metrics	Material	EUT	4	- Alloys easier to be produced with high amount of EoL scrap - Higher fraction of produced powder within the required size range	7
UC 1-3	In-situ thermal monitoring	Monitoring	SINTEF, 3DP	4	Post-process MPM data for use as input in simulation and modelling.	6
UC 1-4	CAE and FEM to optimize printing and thermal profiles	Model	AER, SINTEF	4	Path optimization using machine learning and validated in a commercial machine	6
UC 1-5	Material testing, accelerated fatigue	Material	EUT	5	Reduction of testing time and number of specimens required to obtain the fatigue behavior of metallic materials	7
UC 1-6	Use gathered data and simulation to optimize design and process	Process	AER	7	Use of existing methods	7
UC 1-7	Model propagation of uncertainty	Model	AER	4	Method demonstrated using industrial processes	6
UC 1-8	Identify necessary heat treatment for product	Process	SINTEF, 3DP	N/A	The need has yet to be identified. It is possible that	N/A

## D1.1. Demonstration & characterization requirements analysis

					as-built components will be used. If needed, the technology may be advanced.	
UC 1-9	Surface treatment	Product	3DP	N/A	This technology will not be developed for GEAR-UP, but is used to increase the lifetime of the product.	N/A
UC 1-10	Structured documentation of PBF-LB process	Platform	SCAI	.	Document following standards	8
UC 1-11	Evaluation of standards, data interfaces and semantic concepts	Platform	SCAI	5	Evaluate, adapt, extend and combine existing ontologies	8
UC 1-12	Designing a reference architecture for the GEAR-UP platform	Platform	SCAI, TVS	5	DPP platform, originally developed through various EU-funded projects, will be further enhanced with advanced capabilities.	8

## D1.1. Demonstration & characterization requirements analysis

Table 5: Technology solutions for pelton turbine

UC 2 solution	Technology Solution	Type	Partner	TRL now	Planned Improvements	TRL final
UC 2-1	Recycled composition production of wire feedstock	Product	SIN, AKS, WAG	N/A	Technology for cored wire production is available at WAG. Possible development, but not planned	N/A
UC 2-2	Modelling the variability of trace elements	Model	AER, SIN	4	Model validated in combination with PBF-LB	6
UC 2-3	Resilient building of components	Product	AKS, SIN,	4	Identification, selection and implementation of UC specific areas suitable for repair with DED and recycled materials	6
UC 2-4	CAE including FEM to optimize printing and thermal profiles	Model	AER, FPS	4	Path optimization using machine learning and validated in a commercial machine	6
UC 2-5	Process Monitoring in-situ	Monitoring	SIN, 3DP	4	In-situ thermal imaging with infrared camera will be further developed to explore thermal profiles and their effects on materials.	6
UC 2-6	One way process data mapping	Model	AER, FPS SCAI	4	Combining material and process models with increased recycled content	6
UC 2-7	Material testing, accelerated fatigue	Material	EUT	5	Reduction of testing time and number of specimens required to obtain the fatigue behavior of metallic materials	7
UC 2-8	Modelling the propagation of UQ	Model	SIN AER	4	Predict yield limit and hardness based on predicted thermal	6

## D1.1. Demonstration & characterization requirements analysis

	in process and component design				history during manufacturing	
UC 2-9	Heat treatment selection	Process	SIN, Aker	N/A	Heat treatments specified according to standards will be used initially. If these fail, tailored heat treatments may be developed.	N/A
UC 2-10	Surface treatments	Process	Aker	N/A	This technology will not be developed for GEAR-UP, but is used to increase the lifetime of the product.	N/A
UC 2-11	Structured documentation	Docu	SCAI, ALL		Docu following standards	8
UC 2-12	Semantic Concepts and information platform	Platform	SCAI, TVS	5	DPP platform, originally developed through various EU-funded projects, will be further enhanced with advanced capabilities.	8

## D1.1. Demonstration & characterization requirements analysis

Table 6: Technology solutions for composites from recycled textiles

<b>UC 3 solution</b>	<b>Technology Solution</b>	<b>Type</b>	<b>Partner</b>	<b>TRL now</b>	<b>Planned Improvements</b>	<b>TRL final</b>
UC 3-1	Morphology, mech. properties, chemical interactions, combined with AI	Material	CCR, C4P	4	-	6
UC 3-2	3D printing for products with prescribed properties	Material	CCR, C4P	4	-	6
UC 3-4	Thermally reversible bonds based on Diels-Alder reaction	Material	CCR, C4P	N/A	-	N/A
UC 3-5	Development of a thermally reversible covalently bonded composite system	Material	CCR, C4P	N/A	-	N/A
UC3-6	Semantic Concepts and information platform	Platform	SCAI, TVS	5	DPP platform, originally developed through various EU-funded projects, will be further enhanced with advanced capabilities.	8

## 3 Requirement Analysis – Solution Roadmap

### Task 1.1 Demonstration & characterization requirements analysis

**Phase 3** Finally, phase 3 of the task will formulate a detailed technology development roadmap, ensuring synchronization with the WP5-WP6 development and the WP7 validation plans. This task further involves solution integration strategy definition that will ensure smooth and highly parallel execution of WP8 activities.

- Each listed solution method can be seen as a separate task (see )

*Interactions and dependencies between these tasks can be shown in a workflow graph – also interactions between different use cases and general solutions (see*

- Figure 5)

## D1.1. Demonstration & characterization requirements analysis

- Most solution tasks will be active all the time

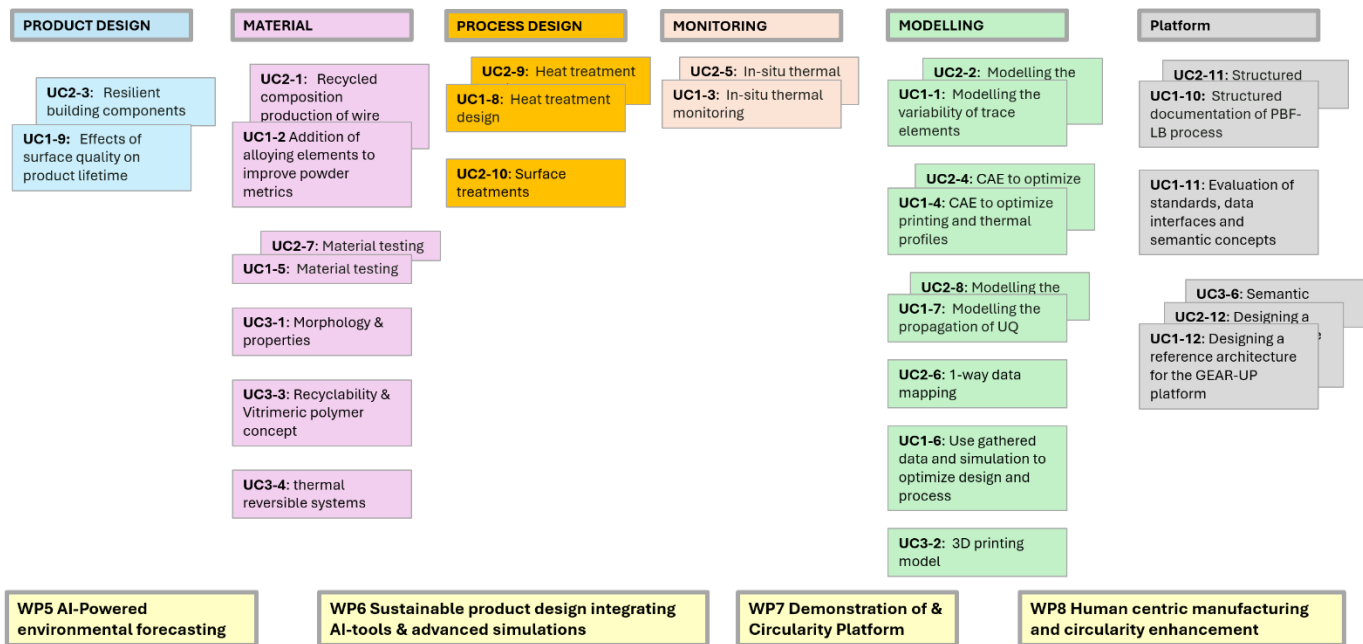
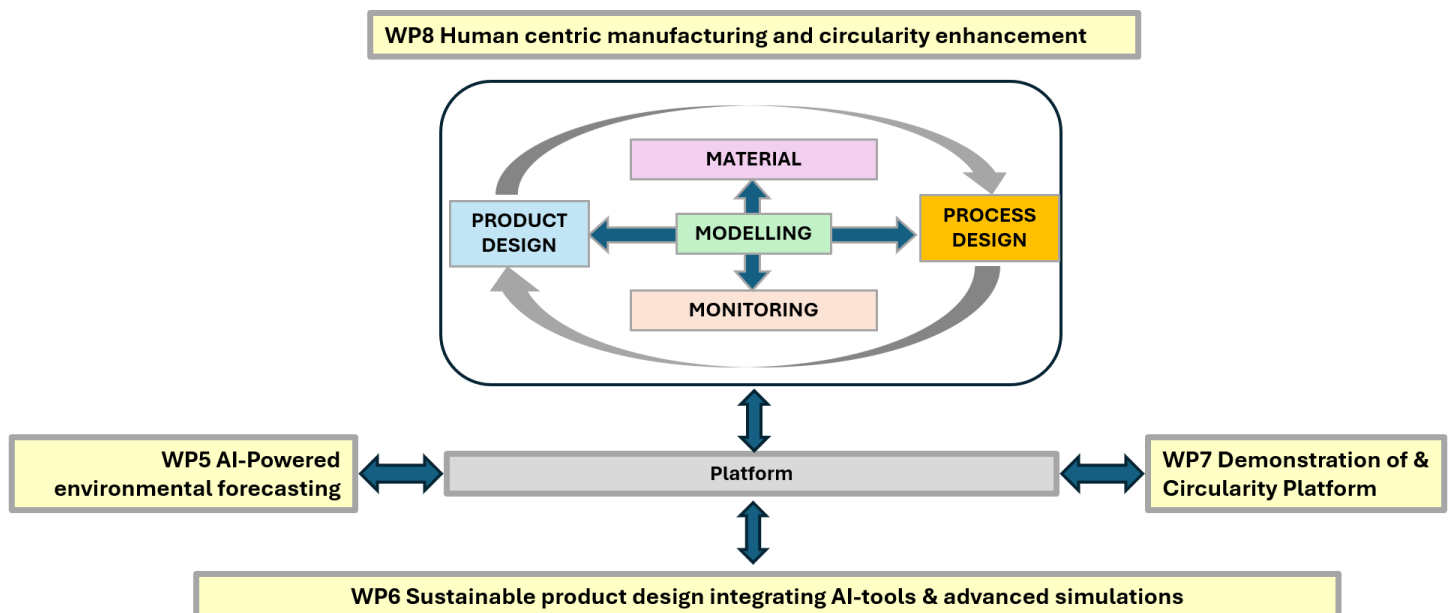

Figure 4. Solutions classified by engineering domain



*Figure 5. Interaction between solutions and major work packages*

## 4 Requirement Analysis – AI powered LCA Roadmap

Developing an AI-powered Life Cycle Assessment (LCA) model requires a combination of technical expertise, high-quality data, and an understanding of environmental impact assessment. The LCA will be conducted in line with ISO 14040 and 14044 which define the general methodology/framework and data requirements for performing environmental impact assessments across a product's life cycle. The relevant environmental product declarations (EPDs) or product category rules (PCRs) like EN 17610:2022, EN 15804:2012, and EN 14025:2006 will support the implementation of the LCA to ensure all and only relevant inputs and methodology are used.

### 1. Goal

- Intended application: The LCA would help to understand the environmental impacts of various design choices with variability of properties and to identify challenges or improvement hotspots. The LCA results of the baseline and alternative scenarios will be compared to assess the improvement in data preparation time and environmental impacts.
- Reason for the study: The main aim of this study is to measure the environmental impacts and identify potential trade-offs between different impact categories across the respective scenarios.
- Intended audience: The results will be shared within the GEAR-UP consortium, but the results of this case study are intended for the use case partners. While the results will be disseminated to the public via scientific publication and reports (e.g. in D5.2: Report describing validation of AI models), this will be done with the required confidentiality in mind.
- The LCA only compares the baseline with the alternative scenarios for this specific case. Therefore, it does not compare across products in the project or across other publicly available products serving the same function. The results will only be presented as potential environmental impacts due to the TRL of this study.

## 2. Scope

- **Product system:** For the LCA study, it is important to gain a good understanding of the product system for this use case and translate this for an LCA flow diagram. This makes it easier to couple the LCA with process (simulation) models and AI tools.
- **Function of the product system:** The key functions of the product system would be defined to enhance the understanding of the expected output/product.
- **Functional unit:** The study must define a common unit of comparison across the respective scenarios for this use case in line with the earlier defined product system.
- **System boundary:** Any technical, temporal, or geographical boundaries must be declared to ensure the study is reproducible. That is, what parts of the product's life cycle are included and excluded. Some examples of this are cradle-to-gate (raw material extraction to factory/customer's gate), cradle-to-grave (raw material extraction to disposal/end-of-life), cradle-to-cradle (raw material extraction to resource recovery), and gate-to-gate (factory gate to customer's gate).
- **Allocation procedure:** To conduct the LCA, it is important to decide how the environmental impacts will be allocated (i.e. mass, economic, hybrid) and what parts of the defined system boundary will be accounted for in the study. Some of the common allocation procedures include cut-off approach (from raw material extraction and use of recycled material to disposal); end-of-life substitution approach (from raw material extraction to material recycling); circular footprint formula (accounting for both recycled content and end-of-life recycling, ensuring closed-loop recycling benefits are properly allocated); and net scrap approach (balancing the environmental burden between primary and secondary material production based on market-based allocation of scrap inputs and outputs).
- **Impact categories:** Climate change (GWP100), ecotoxicity, land use & biodiversity loss, resource depletion, eutrophication, and acidification will be

## D1.1. Demonstration & characterization requirements analysis

assessed in this study based on findings from the literature showing that these are the key areas of risk across this use case.

- Assumptions: To improve reproducibility, all assumptions relating to each use case must be clearly stated.

### 3. Data collection, cleaning, etc

- *Background data:* This study will use the ecoinvent database version 3.10 (available via institutional license at SINTEF Manufacturing) for background LCI data. When the required inventory does not exist or is outdated in ecoinvent, other databases available in SimaPro version 9.6 will be used. Otherwise, the project will use ML tools to pull proxy data or system models from open-source literature studies for use in the LCI.
- *Foreground data:* Foreground data will be generated from the use case partner, process simulations based on standard physiochemical relationships, and literature sources as required. LCA relies heavily on datasets, including material inventories, energy consumption records, emissions data, and supply chain information. AI thrives on high-quality, structured data, so it is essential to obtain a data set that satisfies the needs of AI methods for the development of a meaningful model.

A pedigree matrix will help determine the uncertainty of all data collected, supporting the final LCA model uncertainty calculations. This will be done through focus group discussions with the relevant partners. Data preprocessing and cleaning play a significant role, as inconsistencies or missing values can affect model accuracy.

### 4. LCIA

- LCA modelling: This will be done using SimaPro (traditional approach) and then the AI-based LCA model will be done using ML algorithms to be developed as given below.
- Normalisation: All LCA results will be scaled appropriately to allow comparability across impact categories and facilitate multi-criteria decision-making.

## D1.1. Demonstration & characterization requirements analysis

- **Weighting:** The different impact categories will be assigned weights based on focus group discussions, and based on this, the study can obtain a single environmental impact score for comparing each scenario.

### 5. Uncertainty and sensitivity analysis

Monte Carlo simulation will be conducted for the SimaPro—and AI-based LCA. This will help us understand the uncertainties in the LCA results and the sensitivities of parameters to support decision-making.

The AI component requires a well-designed machine learning (ML) framework. This involves selecting appropriate algorithms, in our case, the supervised ML methods are likely to be used, such as decision trees, neural networks, XGBoost or random forest. It is planned to test several different methods and select the model with the best performance when the LCA data for training and testing is available. A key challenge is ensuring the explainability of AI decisions and making the system transparent and interpretable for LCA practitioners and stakeholders. The solution will be developed in Python and stored in a repository on GitLab. To enhance the model's accuracy, it must be trained on historical LCA case studies and real-world data. Continuous learning mechanisms can improve predictions over time, allowing the model to adapt to new materials, energy sources, or changes in regulations. Validation is another essential step, requiring benchmarking against the established LCA methodology.

Some parameters required to show that the materials, processes, and products are developed sustainably are given in the table below while others will be defined upon gaining a fuller understanding of the scenarios.

*Table 7: Overview of LCA-specific parameters*

Parameters	Description / Justification
Material content distribution in the final product	This includes the weight or share of the main material and other additional materials. E.g. 100% aluminium used for robot gripper
Share of recycled content of the different materials given above	This helps to allocate virgin vs secondary material emissions. E.g. 75% virgin polymer vs 25% recycled

## D1.1. Demonstration & characterization requirements analysis

Class of recycled material used where applicable.	It would be useful to know if the material contains post-consumer scrap, internal scrap, or other pre-consumer scrap. This can make a difference in the benefits of using it.
Country of origin of raw material	This is useful in estimating transport emissions and energy used in raw material extraction.
Country of pre-processing of raw material	This is useful in estimating transport emissions from the country of extraction to the country of semi-production or pre-processing and then onward to production.
Energy use in pre-processing the material	This is useful in estimating the direct energy emissions from the pre-processing stage.
Material losses in pre-processing the material	This is useful in estimating the material emissions from the pre-processing stage. This includes also hazardous or non-hazardous material losses to air, water, and land.
Waste treatment (EoL scenario) in pre-processing	It is useful to know how the material losses in this stage are handled. These can be recycled, incinerated, landfilled, reused, repaired, etc.
Country of final production of use case products	This is useful in estimating transport emissions from the country of semi-production or pre-processing to production.
Energy use in the production of the use case products	This is useful in estimating the direct energy emissions from the production stage.
Material losses from the production of the use case products	This is useful in estimating the material emissions from the production stage. This includes also hazardous or non-hazardous material losses to air,
Waste treatment (EoL scenario) in production	It is useful to know how the material losses in this stage are handled. These can be recycled, incinerated, landfilled, reused, repaired, etc.
Product lifetime (cycles, hours, or years)	Defined either in cycles, hours, or years, the product's expected lifetime is used for scenario analysis to examine any trade-offs between quality and environmental sustainability.
Product EOL handling (recycled, landfilled, incinerated, etc.)	It is useful to know how the final product is typically handled today and how it might be handled in the future. These can be recycled, incinerated, landfilled, reused, repaired, etc.

# 5 Requirement Analysis – Stakeholders’ Workshop

## Task 1.1 Demonstration & characterization requirements analysis

“This Task will organize a preliminary workshop with key stakeholders of the GEAR-UP solution. “

### VMAP User Forum 2025

<https://vmap-standard.org/Events/VMAP-User-Forum-2025/>

This event addressed the growing importance of digitalization and process integration in manufacturing, emphasizing both virtual tasks (like design, simulation and optimization) and physical steps (such as material & part testing and monitoring, system testing). During the meeting we could also see an increasing emphasis on digital product passports, which require well-structured, standardized, and semantically rich data.

The event spanned two days:

- Updates on the VMAP specifications and the ongoing adaptation of tools to the standard.
- Focus on VMAP, its metadata and associated ontologies, as well as solutions for semantic information management in various R&D projects.

Tuesday, 18 February 2025			
10:00	Registration & Networking		
VMAP SC Status			
11:00	Welcome and Introduction	VMAP SC	
11:20	Introduction to VMAP Working Group Activities	VMAP SC	
11:30	VMAP WG – Full Model Definitions	WG Member DLR BT	Complete Model
12:00	VMAP WG – Wrapper Development	WG Member DLR SY	
	Lunch		
Solutions for Workflow & Data Management			
13:20	Enhancing Simulation Workflows – Leveraging VMAP, META, and ANSA for Optimized Results Handling	Beta CAE	BETA CAE
13:50	MpCCI Tools for VMAP – Details about MpCCI tools and extensions	Fraunhofer SCAI	MpCCI
14:10	Metadata & Ontologies – Semantic concepts for digitalisation in manufacturing	Fraunhofer SCAI	FhG SCAI-IMP
	Coffee Break		
Demands from Projects for Semantic Data Organization			
15:00	InShaPe – Challenges in data acquisition and management in additive manufacturing research	TU Eindhoven TU München	InShaPe
15:30	Alabama – The application of VMAP for Additive Manufacturing in regard to workflows, material data and models, sensor data and process specific simulations	SINTEF	ALABAMA
16:00	Pioneer – Open Innovation Platform for Optimizing of Production	AIMEN	Pioneer
	Coffee Break		
Domain Specific Ontological Solutions			
17:00	PMD – Advancing Digital Workflows in Materials Science: The Role of PMDco in Data Integration and Semantic Representation	BAM	PMD Core Ontology
17:30	Bio-Informatics – Semantics & Ontologies	Fraunhofer SCAI	Bio

- Integration platforms and the semantic analysis and AI integration supported by VMAP.

Wednesday, 19 February 2025			
09:30	Welcome		
VMAP Semantics			
9:30	Advanced Laser-Based Manufacturing – Multiphysics Modelling and Interoperability with VMAP Standard	Aerobase AB	GEAR-UP RESTORE
10:00	DIMAT – Bridging Interoperability Gaps in Manufacturing with a Bottom-Up Approach to Managing Semantics	FhG IWM	DIMAT
10:30	BASE – Battery Passport for Resilient Supply Chain and Implementation of Circular Economy	Fraunhofer SCAI	BASE
	Coffee Break		
VMAP in Industry			
11:00	GGS – Groeien in Green Steel	Philips RUG	GGS
11:30	Demands from Standardisation for Automotive Industry	VW	
12:00	Discussion on semantics & metadata management	All	
	Lunch		
13:30	VMAP Strategy – Organizing Data for Analysis	VMAP SC	

### Key Highlights:

- Extension & Advancement of VMAP: DLR presented the current developments of the working group and spoke about the importance of wrappers to streamline the data transfer to VMAP Standard.
- Additive Manufacturing: Critical insights on standardizing data for powder bed laser processes (Inshape) and the versatility of laser DED showcased through ALABAMA Project and **GEAR-UP Project** use cases presented by SINTEF Manufacturing.
- Open Innovation Platform: Introduction of the PIONEER project platform by AIMEN Centro Tecnológico
- Materials Science: Plattform MaterialDigital PMDco presentation by Bundesanstalt für Materialforschung und -prüfung featuring a lightweight mid-level ontology for materials science and engineering (MSE)
- Multiphysics Modelling: Aerobase Innovations AB presentation on laser-based manufacturing standards with use cases from RESTORE - Sustainable Remanufacturing, ALABAMA & **GEAR-UP** project.
- Semantic Manufacturing Data: DiMAT project's bottom-up approach to semantic data management
- Sustainable Production: GGS project's vision for environmentally responsible "green steel" manufacturing
- Battery Passport Innovation: Semantic modelling as a cornerstone of the BASE EU: Battery Passport for Transparency & Circularity developing comprehensive digital battery passports
- Automotive Transformation: Volkswagen's presentation on shifting paradigms in the auto sector, featuring virtual testing and certification processes and the demand for data standardization.

In the discussions following the individual lectures and in the final discussion on the second day, the need for special adaptations and extensions to the VMAP standard for the field of additive manufacturing became clear.

A second important point is the need for more collaboration between as many R&D projects as possible in which semantic information concepts play a role. Fraunhofer SCAI will initiate further follow-up meetings on specific topics of semantic modelling (ontologies) and data standardization via the VMAP SC.

## 6 Key Metrics Task 1.2

To establish a foundation for a successful project outcome, inputs and outputs from respective use-cases are hereafter defined in a key-metric analysis. The analysis includes specifications related to acceptable compositions of the recycled materials, process parameters and acceptance criteria for the final components.

Each use case is divided into three different categories based on the evaluated key-metrics:

- Key Metrics – Material
- Key Metrics – Process
- Key Metrics – Product

Furthermore, input parameters are synonymous with **process** and **material** key metrics. Output parameters are more closely tied to the final properties of the **products**, which can also be evaluated as key performance indicators (KPIs). Note, however, that input parameters are preliminary. As the project produces results, and knowledge on output parameters increases, input parameters will be subject to change to achieve the predefined KPIs. Metrics presented in this delivery are defined in part by consortium partners and literature, but also applicable standards.

## 6.1 Key Metrics for the Materials

The GEAR-UP initiative works with three different materials, two metal alloys and one polymer composite. The presence of trace elements in recycled metals can significantly alter their properties and cause changes in microstructure.

Taking the martensitic stainless steel from use-case 2 as an example, increased carbon content may make it prone to desensitization during heat treatment. This could occur due to precipitation of chromium carbides, which causes chromium depletion in the microstructure and initiates pitting corrosion through micro-galvanic cells. Furthermore, increased carbon content is known to make these steels unweldable. Welding causes austenization during heating, which forms brittle martensite during cooling (trapped carbon). In addition, chromium nickel equivalents and martensitic transformation temperatures may be altered due to trace elements. Studies conducted by AER, show that trace elements can lead to early failure and reduced plasticity. Some trace elements may induce embrittlement, solidification cracking and create inclusions that lead to anisotropy and reduced ductility. In addition, trace elements affect thermal gradients and nucleation during deposition, which may influence columnar-to-equiaxed (CET) transitions. To mitigate these challenges, GEAR-UP will aim to characterize these effects more clearly through testing and predictive modelling, better defining what degree of trace elements are permissible for adequate quality of the final components given an optimized AM process.

All use-cases will use certain material parameters as input for simulation and modelling efforts. These parameters vary with temperature and phase. Temperature dependent Young's modulus, Poisson's ratio, flow stress, specific heat and heat conductivity are required in the additive manufacturing analysis for metallic materials. The flow stress, thermal dilatation (thermal expansion + volume change due to phase transformation) and latent heat is also dependent on the

microstructure evolution. In AM, the material is exposed to high temperature during a long time so stress relaxation (plastic flow) can also be important to include. For polymer material, temperature dependent viscoelastic properties (rate dependent elastic properties) and glass transition temperature ( $T_g$ ) must be included in the model.

### 6.1.1 Robot Gripper – Material metrics

Aluminum is a lightweight, relatively cheap and versatile material that exhibits good strength at a low weight. This, combined with good corrosion resistance, makes it a perfect candidate for many industrial environments. AlSi10Mg is one of the most common aluminum alloys, originally alloyed for cast components. It is traditionally hardenable through artificial aging and extensively used for laser beam powder bed fusion (PBF-LB). Desired compositional range according to EN 1706 is shown in Table 8.

Table 8: Standard composition for AlSi10Mg powder

CHEMICAL COMPOSITION AS SPECIFIED BY DIN EN 1706													
ELEMENT	Al	Si	Mg	Fe	Mn	Ti	Zn	Cu	Ni	Pb	Sn	Other	Total other
<b>MIN</b>	Bal.	9.00	0.20										
<b>MAX</b>	Bal	11.00	0.45	0.55	0.45	0.15	0.10	0.05	0.05	0.05	0.05	0.05	0.15

In addition to this standard composition, additional compositions will aim to imitate the obtention from end of life (EoL) scrap. The main difficulty in obtaining the standard AlSi10Mg from scrap is the limited amount of Cu and Zn that the standard allows. To evaluate the possibility of obtaining it with a large fraction of scrap, the effects of impurities such as Cu and Zn will be evaluated. Two different levels of these two impurities will be studied, see Table 9.

## D1.1. Demonstration & characterization requirements analysis

The effect of other alloying elements, namely Si and Mg will also be evaluated, as they may exhibit positive effects on powder process metrics such as flowability, wettability and average particle size. Compositional ranges for secondary material powders are provided in Table 9.

Table 9. Compositions that imitate secondary material with recycled contents

CHEMICAL COMPOSITIONS IMITATING SECONDARY MATERIAL													
ELEMENT	Al	Si	Mg	Fe	Mn	Ti	Zn	Cu	Ni	Pb	Sn	Other	Total other
MIN	Bal.	11.00	0.45				0.20	0.20					
MAX	Bal	12.00	0.65	0.55	0.45	0.15	0.30	0.30	0.05	0.05	0.05	0.05	0.15

The alloy flowability and wettability will be assessed for each possible composition, to determine the effect of each element on properties and the possible interaction between them.

### 6.1.2 Pelton Turbine – Material Metrics

This use-case utilizes 13 %Cr-4 %Ni stainless steel. With its composition of alloying elements, the chromium nickel equivalents of these steels suggest that they will undergo a martensitic and ferritic transformation upon solidification. While complex, and yet to be fully understood, martensitic transformation occurs upon nucleation in prior austenite grains and grows with a certain orientation relationship relative to these.

Carbon and chromium are the main alloying elements in this group of steels. Originally, however, carbon would lead to difficulties regarding poor weldability, cracking and reduced toughness. Since the 1960s the steel employed in this use-case was developed, with additions of Nickel to reduce delta ferrite. Examples include but are not limited to 13%Cr-4%Ni, 16%Cr-6%Ni and 17%Cr-6%Ni. Among these, 13%Cr-4% has seen extensive use in the fabrication of hydraulic turbines due

## D1.1. Demonstration & characterization requirements analysis

to good corrosion resistance, excellent weldability and resistance to erosion/cavitation. When certified according to EN 10250 for forged stainless steels, the steel should have a composition in ranges presented in Table 10.

*Table 10: The desired range of composition in 13-4 soft martensitic stainless steel*

CHEMICAL COMPOSITIONS AS SPECIFIED IN EN 10250-4									
Element	C	Si	Mn	P	S	Cr	Mo	Ni	N
<b>Min</b>						12	0.30	3.50	0.020
<b>Max</b>	0.05	0.70	1.50	0.040	0.015	14	0.70	4.50	

During the project, tests will be done on representative recycled material restructured into cored wire feedstock. Possible sources and compositions for the recycled material during the project are to be selected from:

- Process machine chippings produced during traditional machining of Pelton turbine buckets. This would create a desirable and more circular product for Aker Solutions. Machining waste generated by machining workshops or manufacturing plants is likely to be mixed with other materials that have been processed with the same machining tool, providing a perfect case for GEAR-UP to investigate and limit the effects of trace elements. Due to cross contamination and remnants of cutting fluids, such chips are often discarded as waste. Characterization of the swarf composition from Aker will form the basis of selected chemical compositions to represent recycled material.
- Used powder from the PBF-LB process with a similar composition. 13-4 steel is not typically used in the PBF-LB process, however similar compositions such as 17-4 steel are more common and when recycled could be suitable for the Use Case with the DED-process with or without much change.
- Oversized and processed waste powder from PBF-LB. Powder morphologies after the PBF-LB process, typically disposed of as waste, may be suitable for wire

## D1.1. Demonstration & characterization requirements analysis

fabrication and use case material. The morphological deviations such as oversized particles and satellites may affect the formability of the wire and consistency of material properties.

The composition of Table 10 will be used as a benchmark to which recycled compositions can be compared. Selection of exact compositions and variations for modeling will depend on the source of recycled material and capability for removal of contaminants/elements during wire fabrication. These are to be determined in the first phase of the project. Where, as an example, the detrimental effects on microstructure and properties from common impurity elements such as Cu and Sn, and loss of elements such as Cr and Ni mean most impure steel scrap is rather downcycled than used for high performance parts in sheet steels.

### 6.1.3 Composite with recycled textiles – Material Metrics

For this use-case fiber-reinforced PLA with titanium dioxide particles will be used. Therefore, the material used will be a mixture of PLA reinforced with fiber and titanium dioxide particles, which provides a good balance of strength, stiffness and wear resistance. The main materials metrics for this use-case can be classified in two main categories:

#### **1. Nanocellulose Content:**

- Quantification: The composite's formulation will be characterized by the amount of nanocellulose reinforcements incorporated (measured in kg) and the overall share of recycled content in the final material.
- Source & Pre-processing: Emphasis is placed on ensuring that the textiles are derived from post-consumer scrap or industrial offcuts pre-processed to remove contaminants.

#### **2. Material Properties & Performance:**

## D1.1. Demonstration & characterization requirements analysis

- **Mechanical Behavior:** Including nanocellulose fibers will enhance the composite's tensile strength and impact resistance while maintaining a low overall density.
- **Thermal Stability:** Given the variable temperature conditions experienced by Vidde snowmobiles, the composite must exhibit consistent thermal expansion behavior and maintain its structural integrity at sub-zero temperatures.
- **Bonding & Homogeneity:** Special attention is required to achieve uniform dispersion of recycled fibers within the polymer matrix. Inhomogeneities or fiber misalignment could lead to local stress concentrations, impacting overall durability.

## 6.2 Key Metrics for the Processes

Key process metrics for the respective use-cases are presented below. Note that these are subject to change throughout the project duration due to iterative improvement. The lists are also preliminary and non-exhaustive, meaning that additions may be made.

### 6.2.1 Robot Gripper – Process Metrics

Quantification and identification of process related key-metrics for laser beam powder bed fusion (PBF-LB) for production of the robot gripper is presented below in Table 11.

Table 11: Process metrics used in production of robot gripper

Process metrics for machine	Quantification
Machine	Brand, serial number, year
Build size options	Width * length (of build plate) * height
Pre-heating (C°)	0-200
Protective gas	Argon
Chamber pressure (mbar)	1-15
Gas consumption (l/min)	0-3
Build rate $cm^3/h$	26.6
Process metrics for laser system	Quantification
Spot size laser ( $\mu m$ )	up to 100
Laser profile	Gaussian
Laser speed (mm/s)	800-10000
Laser power (W)	200-700
Powder metrics	Quantification
Layer thickness ( $\mu m$ )	20 – 100
Particle size ( $\mu m$ )	20-63 $\mu m$ (63 to 120 $\mu m$ range can be also produced)
Morphology	Sphericity > 0.70
Apparent density $g/cm^3$	Minimum 1.3
Flowability	40s for 50g of powder

In-process measurements	Quantification
Oxygen content (ppm)	2-500
Melt pool monitoring	MPM system with 10kHz measurement rate
Laser strength measurement	System is capable of measuring laser strength in W
Post processing	Quantification
Heat treatment	Solution annealing 30 min at 530 C° followed by water quench. Aging at 165 C° for 6 hours followed by air cooling.
Machining	TBD

### 6.2.2 Pelton Turbine bucket head – Process Metrics

Quantification and identification of process related key - metrics for laser beam directed energy deposition (DED-LB) for production of the turbine are presented below in Table 12.

*Table 12: Process metrics for repaired section of pelton bucket head, manufactured by DED-LB*

Process metrics for machine	Quantification
Machine	KUKA robot mounted with Meltio head
Pre-heating	TBD
Protective gas	Argon
Gas consumption (l/min)	10-20
Process metrics for laser system	Quantification
Spot size laser (mm)	0.7
Laser profile	Gaussian
Laser formation	Standard formation
Traverse speed (mm/s)	10-15
Laser power (W)	750-1500
Wire metrics	Quantification
Wire diameter (mm)	1 or 1.2
Recycled content (%)	5-20%
Build metrics	Quantification

## D1.1. Demonstration & characterization requirements analysis

Feed rate (mm/s)	15-30
Interpass temperature (°C)	TBD: As understanding of martensite transformation temperature increases, a suitable interpass temperature will be selected
<b>In-process measurements</b>	<b>Quantification</b>
IR-Camera	Infratec VarioCAM HD Head 800
IR-Camera Spectral range (µm)	7.5-14
IR-camera temperature measuring range (°C)	-40-2500 C°
IR FOV at 0.1 working distance (µm)	180
<b>Post processing</b>	<b>Quantification</b>
Heat treatment (°C)	590 ± 10 at 4 min/mm thickness. Minimum 4 hrs

In addition to the DED-LB process used for part manufacturing, welding alloys will produce the wire that is used.

### 6.2.3 Composite with recycled textiles – Process Metrics

The drive sprocket is produced using an additive manufacturing process tailored to handle composite materials. Process parameters will be fine-tuned to accommodate the presence of recycled textiles. The parameters that will be controlled are presented in Table 13.

Table 13: Process metrics for 3D-printed Drive Sprocket for Snow Mobile drive train

General process metrics	Quantification
<b>Machine</b>	Brand, model, manufacturing year
Build volume – l, w, h, (mm)	(300 × 300 × 100)
Build Plate Temperature (°C)	90
Humidity (%)	35
Process Metrics for the Extruder/Nozzle	Quantification
Nozzle Diameter (mm)	0.6–0.8
Extrusion Temperature (°C)	230–250
Max Extruder Heating Uniformity ( $\Delta T^{\circ}\text{C}$ )	30
Print Head Traverse Speed (mm/s)	25
Mean extrusion rate (mm <sup>3</sup> /s)	50
<b>Filament Properties</b>	
Diameter (mm)	2.85
Fibre (% by weight)	35 (20–50)
Build Metrics	Quantification
Build Time (h)	4
Component Weight (kg)	0.8
In-Process Measurements	Quantification
Embedded Temperature Sensors (°C)	±2.5
Dimension of printed object (mm)	±0.5
Post-Processing	Quantification
<b>Milling</b>	
Surface roughness (µm)	1.6

## 6.3 Key Metrics for the Products

Key product metrics stand as overarching goals the different use-cases aim at fulfilling throughout the project. Whenever possible, applicable standards are used to see if the components meet industrial demands. Additional requirements are also set by consortium members in cases where standards do not cover properties or details of the GEAR-UP project that deserves further research.

### 6.3.1 Robot Gripper – Product Metrics

Having been extensively researched in the context of PBF, AlSi10Mg is supplied with material datasheets that cover material related product metrics. Furthermore, an abundance of research has accurately quantified the heat treatments necessary to achieve optimal properties. Repeatability and reproducibility are only ensured for certain sets of process parameters and powder quality which will be established through the GEAR-UP project, also with incorporation of emulated recycled material. The economic and environmental aspects of the use-case are covered by two major points:

- Environmental and economic impact of exchanging components that are typically built in titanium with aluminium
- Utilizing more secondary material in the manufacturing process.

Important key product parameters and KPIs are shown in Table 14.

*Table 14: Product metrics for the robot gripper*

Quality of product	Quantification
Surface roughness ( $\mu\text{m}$ )	Ra 0.8-1.6 (machined), 3-40 (as-built)
Yield strength $R_{p0.2}$ (MPa)	>230 as-built (>250 heat treated)
Ultimate tensile strength (MPa)	>450 as-built (>310 heat treated)
Elongation (%)	4-7 as-built (8-9 heat treated)
Charpy impact energy ( $\text{J}/\text{cm}^2$ )	4.5 as-built (2.5 heat treated)

Morphology grain structure	Fine cellular $\alpha$ -Al with intercellular eutectic Si (as-built), coarsened cellular $\alpha$ -Al with large Si-agglomerates (heat treated) eutectic Si
Quantity defects/porosity (%)	0.2 as-built
Max defect size ( $\mu\text{m}$ )	150
Fatigue strength (MPa)	110 (lower limit as-built)
Fracture toughness ( $\text{MPa}\sqrt{\text{m}}$ )	27-37
Hardness (HV10)	114 as-built
Corrosion resistance	Corrosion Potential => In the range -1V to -0,75 V vs Ag/AgCl in sea water (NaCl 3.5%) Current Density => In the range 0.5 to 5 $\mu\text{A}/\text{cm}^2$ in sea water (NaCl 3.5%)
Density ( $\text{g}/\text{cm}^3$ )	$\geq 2.66 \text{ g}/\text{cm}^3$

### 6.3.2 Pelton Turbine – Product Metrics

Pelton buckets are typically either cast or forged and are subjected to harsh conditions during their lifetime. Large dynamic loads, high water velocities and demanding operating medium require them to be fatigue resistant, strong, and resistant to the synergetic effects of corrosion and erosion. Forging and subsequent machining leads to high material waste during manufacturing of such components. Material waste stands to be severely reduced if these products can be produced directly through DED. Furthermore, when produced, DED offers the possibility of repair instead of rendering obsolete parts, increasing the lifetime of turbines through a sustainable approach. Depending on whether entire parts are produced, or simple repairs are being carried out, different certification criteria will have to be applied. Sharing many similarities with welding, repair with DED-LB may utilize welding standards/certifications and standards for the substrate material to ensure adequate properties. If a new part is to be produced, AM certification standards such as DNV-ST-B203 or API 20S may be more fitting, covering everything

## D1.1. Demonstration & characterization requirements analysis

from metallurgical testing, NDT evaluation and part criticality. Regardless, it needs to be ensured that either repaired section, or the entire component, demonstrates similar or better quality to that of forged base metal. Key product metrics in a use-case involving repair of Pelton turbines are shown in Table 15. These are expected outcomes of using primary material.

Table 15: Product metrics for the repaired section of Pelton turbine bucket head

Quality of product	Quantification
Surface roughness (Ra)	0.8 or 1.6, machined surfaces after DED
Phase composition (%)	Max 5% delta ferrite, 15% austenite. Predominantly tempered martensite
Yield strength $R_{p0.2}$ (MPa)	Min 520
Ultimate tensile strength (MPa)	650 to 830
Longitudinal elongation (%)	15
Transverse elongation (%)	12
Longitudinal impact energy KV2 (J)	70
Transverse impact energy KV2 (J)	50
Impact toughness at 0°C (J)	27
Morphology grain structure	Equiaxed fine prior austenite grains: LOM, SE and EBSD
Defect sizes ( $\mu\text{m}$ )	$\leq 100$
Fatigue limit/strength (MPa)	Similar or better than forged material
Hardness	TBD
Erosion-Corrosion resistance	Damage evaluated with LOM and SEM, infinite focus microscopy, potentiometry measurements with quantifications of mass loss.

### 6.3.3 Composite with recycled textiles – Product Metrics

Drive sprockets for snowmobiles are typically manufactured by injection molded thermoplastic materials. The cogs in the sprocket are in contact with the track cogs made of rubber but also supported by a steel insert. The wear on the drive sprockets usually comes from contact with the steel inserts at high torque load. The maximum

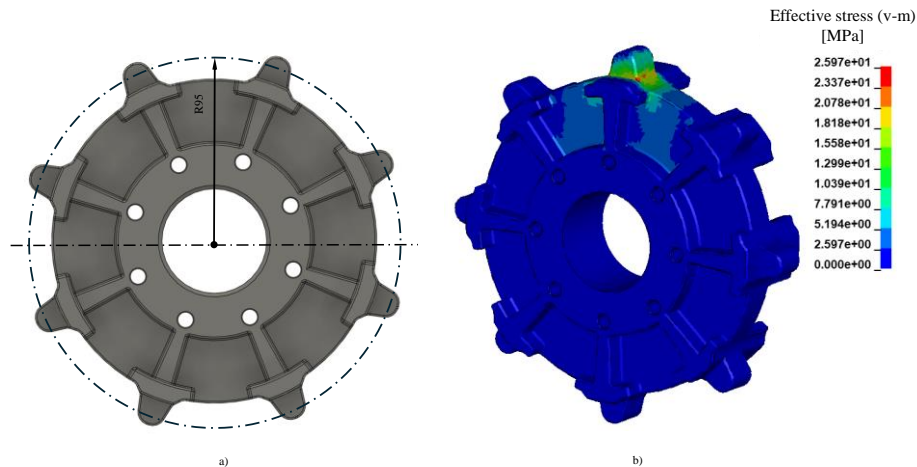

torque load is 500 Nm divided by two sprocket wheels. In worst case scenario, only one of the cogs transfer a load of 250 Nm. The center of the contact area between the cogs on the drive sprocket and the track is approximately 95 mm from the center of the wheel, Figure 6.

Figure 6. a) Drive sprocket geometry with the distance from center to the center area of contact. b) Predicted stresses in Drive sprocket during maximum load.

The stress (v-m) at maximum load is predicted to be approximately 26 MPa (Young’s modulus,  $E=1000\text{MPa}$ ) with a maximum deformation of 0.7mm on the top of the cog.

General product metrics	Quantification
Surface Roughness Ra ( $\mu\text{m}$ )	1.6
Youngs modulus up to 1% strain – tensile (MPa)	1000
Youngs modulus up to 1% strain – compression (MPa)	800
Longitudinal Yield strength (MPa)	30
Transverse Yield strength (MPa]	30
Longitudinal Elongation (%)	10

## D1.1. Demonstration & characterization requirements analysis

Transverse Elongation (%)	10
Creep resistance at 1 MPa during 1000h (%) ISO 899-1,2, option DMA test	1
Fatigue Limit/Strength (cycles at MPa) DMA test	17.000.000 cycles at 5 MPa
Fracture Toughness @ -20°C (J/cm <sup>-3</sup> )	15.0
Hardness Ball Indention Hardness ISO 2039-1	60
Density (kg/m <sup>3</sup> )	1000-2000
Defect size on cogs contacts surface (mm)	0.5
NDT Tests	Hardness

### 6.4 Conclusion on key metrics

**For use case 1 the following key metrics have been identified:**

- While the gripper is not subjected to many of the degradation mechanisms evaluated in GEAR-UP, there is a desire to optimize material properties and quality for future application of recycled material in more demanding applications.
- Material properties should be better than cast material.
- As-built porosity should be under 0.2% with a maximum defect size of 150 µm.
- Process parameters and post processing (heat treatment and machining) should be optimized to grant highest possible quality and long lifetime.
- Demonstrate the environmental impact of using recycled aluminium in the PBF process through an LCA.

**For use case 2 the following key metrics have been identified:**

- No tolerated as-built surfaces, due to negative effects on corrosion and fatigue.

## D1.1. Demonstration & characterization requirements analysis

- Properties should be on par or better than the forged base material on which repairs will be done.
- Optimal balance between martensite and austenite to ensure sound properties.
- Deposition and PWHT should have no detrimental effects on substrate material.
- Demonstrate how circular supply can be adopted through increased recycling of machining chips/swarfs and powders from other processes.
- Demonstrate the environmental impact of using recycled stainless steel to produce wire for the DED manufacturing process through LCA.

### **For use case 3 the following key metrics have been identified:**

- Evaluate the design and weight when using circular material in a drive sprocket application.
- Compare the environmental impact using a circular and a reference in fossil-based polymer material.

### **General Conclusion:**

#### **Input parameters**

Several input parameters have been defined, both for the materials and processes that will be used in GEAR-UP. These are parameters that influence the manufacturing process and aid us in understanding how simulations can and should be built. As the project progresses, input parameters crucial to conducting the LCA will also be defined and quantified.

#### **Output parameters**

Representing desired outcomes and quality metrics, output parameters serve as criteria for controlling results of the manufacturing processes.

**Variation between cases:**

Different production methods, materials and end-user requirements cause considerable variation between the different use-cases. Understanding these differences will be crucial for optimization of the product, as well as conducting the LCA.

**Development:**

Progression of the project and deeper understanding will cause continuous development of key metrics and system boundaries for the LCA. This key metrics analysis together with the requirement analysis stands as a guide for respective partners to fulfill the goals established through the proposal, while introducing a foundation for further conceptualization.

